



Since 1966

**ALAN PRE-FAB BUILDING CORPORATION**

Contractor's License #269618

**DATE:** 6/29/2001 **PROPOSAL** | 6/29/2001

XX 17817 Evelyn Ave. Gardena CA 90248-3735  
Tel: 1 310 538 0333 Fax: 1 310 538 0436  
e-mail: bandrus@alanprefab.com

Name	<b>Phone:</b> 000 000 0000
Company	<b>Project:</b> 4'x5' Deluxe Guard House Wood Frame
Street	<b>Fax:</b> 000 000 0000
City,St,zip	<b>e-mail</b> none

**We appreciate the opportunity to quote on your requirements:**

- Project: 4'x5' Deluxe Guard House Wood Frame **Alan Model # 04058121**
- Basic Building. Skid Mounted on 4x6 pressure treated skids
  - Interior - Lined
  - Insulation- R-11 Walls, R-19 Ceiling
  - 1/4" Birch wood interior paneling over 2x4 studs, 16" on center
  - 1/2" taped and painted gypsum board ceiling over 2x6 joists 24" on center
  - 1/8" V.C. Floor tiles, Armstrong over 3/4" T&G plywood and 2x6 joist 16" on center
  - 5/8" T-111 exterior siding with metal trimout. Painted: Beige,Off White, Grey, Blue, Dark Brown
  - Lo Profile roof design. 30 G galvanized steel over 1/2" CDX plywood underlayment
  - 1 -3-0x6-8 C7 steel clad entry door, with lever passage set and deadbolt (18"x18" clear glass insert)
  - 3 -Windows - 3-0x2-6 Aluminum sliding windows, clear glass
  - 0 -Windows - 4-0x2-6 Aluminum sliding windows, clear glass
  - 4 -16" Melamine Counter, interior
  - 1 -Electrical Subfeed Load Center, 60 Amp, Single Phase, snap in circuit breakers
  - 2 -Duplex receptacles
  - 1 -Light switches (50% reduction for rooms over 100 S.F.)
  - 1 -4 ft, 2 bulb Fluorescent light fixture, with lamps and lense covers
  - Delivery to: Los Angeles Basin to best access, unloading by others (requires forklift or crane)

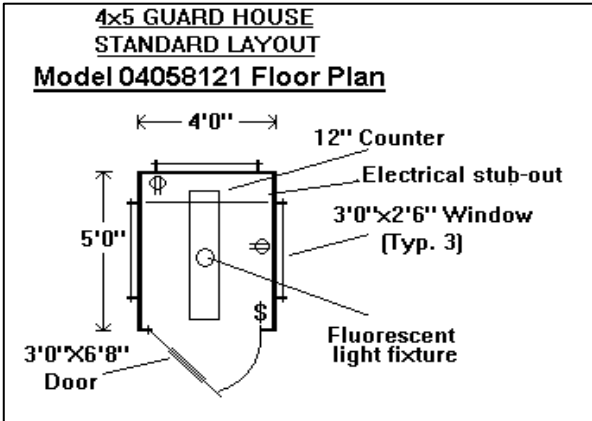

**BUILDING PURCHASE PRICE:**  
 \$3,240 Each, Plus applicable taxes  
 FOB Los Angeles Basin  
 See extended Freight  
 Schedule for 48 State  
 Freight Charges

**Option:** -3/4 ton Friedrich air conditioner/heater, room unit, 120V, frame, wiring & installation  
**PURCHASE PRICE:** \$1,100 Each, Plus Applicable Taxes

Items not included: Any features not specifically listed in proposal.

**PAYMENT TERMS:** 1/3 Deposit, Balance due when ready for delivery. Or negotiated with credit approval  
Other purchase terms apply per Additional Terms, Covenants, and Conditions of Sale

Acceptance: The specifications, conditions, and payment terms are agreed to: By: X  
Please return one copy. Order will be commenced upon our receipt of signed proposal, and deposit (if required).