



Since 1966

**ALAN PRE-FAB BUILDING CORPORATION**

Contractor's License #269618

XX 17817 Evelyn Avenue, Gardena CA 90248-3735 U.S.A.  
Tel: 1 310 538 0333 Fax: 1 310 538 0436  
e-mail: bandrus@modularbuildings.biz  
Sales Rep:

**DATE:** 3/20/2014

**PROPOSAL NO:** 41718-0405UL

**Attn:** Contact  
Company  
str.

**Phone:** 000 000 0000  
**Project:** 4'x5' Basic Guard House Wood Frame  
**Fax:** 000 000 0000  
**e-mail:** none

city, st, zip

**We appreciate the opportunity to quote on your requirements:**

Project: 4'x5' Basic Guard House Wood Frame Wood Frame **Alan Model # 04058721**  
-Basic Building. Skid Mounted  
-Interior - Unlined, exposed framing interior  
-Insulation- none

- Painted floor, 3/4" T&G plywood decking
- 5/8" T-111 exterior siding with metal trimout. Painted: Beige, Off White, Grey, Blue, Dark Brown
- Lo Profile roof design. 30 G galvanized steel over 1/2" CDX plywood underlayment
- 1 -2-6x6-8 RLC7 steel clad entry door, with lever passage set and deadbolt (18"x18" clear glass insert)
- 3 -Windows - 3-0x2-6 Aluminum sliding windows, clear glass
- 0 -Windows - 4-0x2-6 Aluminum sliding windows, clear glass
- 1 -Electrical stubbed to exterior for hard wire connection
- 1 -Duplex receptacles
- 1 -Light switches (50% reduction for rooms over 100 S.F.)
- 1 -Incandescent light socket
- 4 -LF counter top, 12" deep, with 3/4" Melamine top
- Delivery to: Los Angeles Basin to best access, unloading by tilt bed truck

**PURCHASE PRICE: \$3,260** Plus applicable taxes

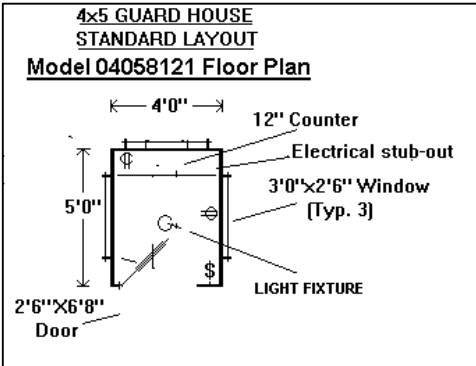

Items not included: Any features not specifically listed in proposal.

**PAYMENT TERMS:** 1/3 Deposit, Balance due when ready for delivery. Or negotiated with credit approval  
Other purchase terms apply per Additional Terms, Covenants, and Conditions of Sale

This proposal may be revised or withdrawn by us after: Thirty days from proposal date  
Acceptance: The specifications, conditions, and payment terms are agreed to: By: X  
Please return one copy. Order will be commenced upon our receipt of signed proposal, and deposit (if required).